

DAE Pumps Tampa 6110

Submersible
Slurry and Sand Pump



DAEPUMPS.COM

info@daepumps.com

(760) 821-8112

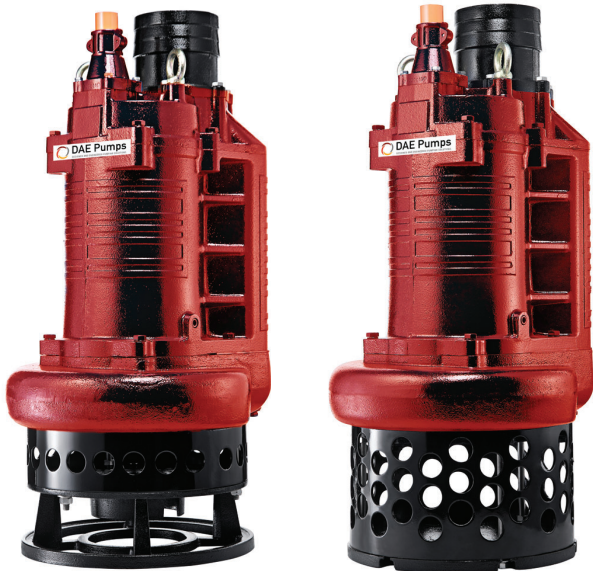

Opened Impeller

Strainer Impeller

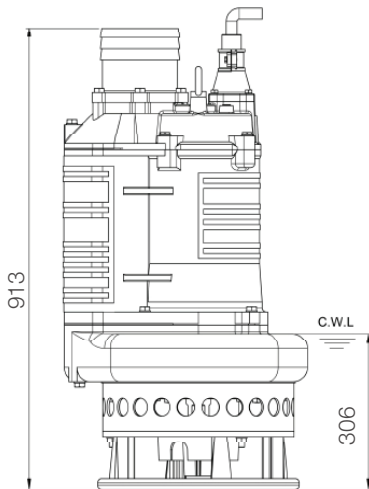
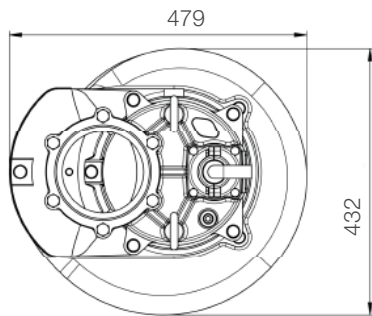

unit : mm

Weight : 192kg / 423 lbs

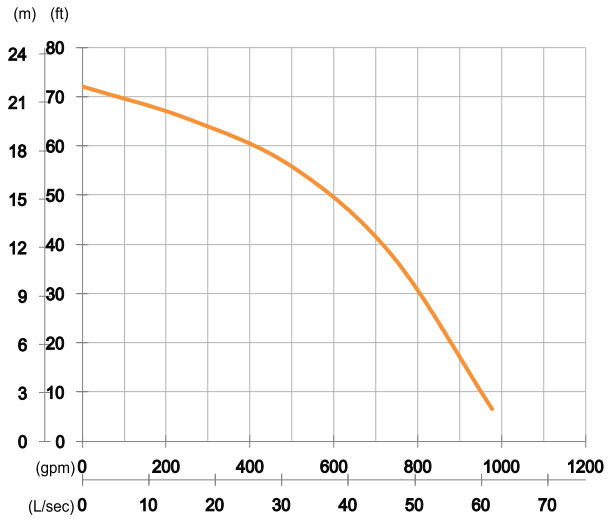

Shaft Speed : 1750 rpm

Outlet : 150mm, 6in

| OUTPUT | HEAD | FLOW |
|--------|-------------------|---------------------------|
| 11 kW | Rated : 17m, 56ft | Rated : 31.7 L/s, 502 gpm |
| 15 HP | Max : 22m, 72ft | Max : 61.7 L/s, 977 gpm |

Solid Passage : 35mm, 1.4in

| | | |
|-------------------------|-------------|-------------------------------------|
| Pump Type | | Electric Submersible Pumps |
| | | 3-Phase |
| Motor | Type | Induction Motor |
| | Poles | 4 Pole |
| | Insulation | Class F |
| | Protector | Circle Thermal Protector |
| | Starter | D.O.L. |
| Lubricant | | Food Grade (ISO VG32) |
| Impeller Type | | Opened or Strainer Options |
| Shaft Seal | | Double Mechanical Seal |
| | | Silicon Carbide VS Ceramic / Carbon |
| Bearings | | C3 Shielded ball bearings |
| Cable | | PVC (CSA Certified) / H07BQ-F |
| | | 10m (33ft) or longer upon request. |
| Materials | Pump Casing | Ductile Iron |
| | Impeller | Chromium Iron |
| | Motor Frame | Gray Iron |
| | Motor Shaft | Stainless Steel |
| | Wear Plate | Chromium Iron |
| | Agitator | Chromium Iron |
| Max. Liquid Temperature | | 40°C (104°F) |
| Max. Submersion Depth | | 20m (66ft) |
| pH Range | | pH 5 - pH 8 |