

DAE Pumps Tampa 475

Submersible
Slurry and Sand Pump



DAEPUMPS.COM

info@daepumps.com

(760) 821-8112



Opened Impeller

Strainer Impeller

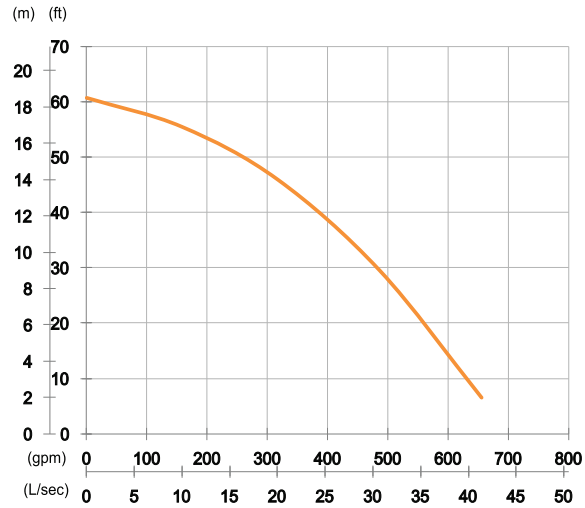

Shaft Speed : 1750 rpm

Outlet : 100mm, 4in

OUTPUT	HEAD	FLOW
7.5 kW	Rated : 14m, 46ft	Rated : 20 L/s, 317 gpm
10 HP	Max : 18.5m, 61ft	Max : 41.3 L/s, 655 gpm

Solid Passage : 25mm, 1in

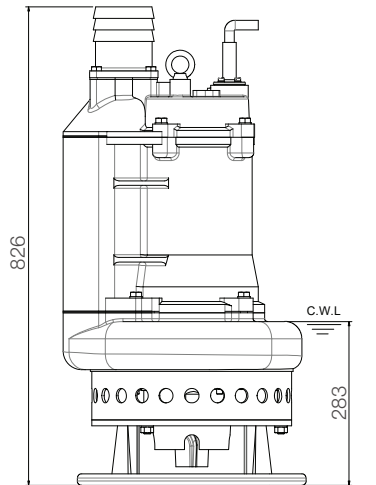
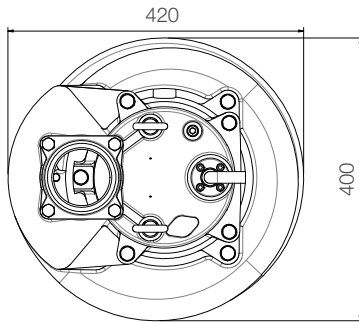

unit : mm

Weight : 124kg / 273 lbs

Pump Type	Electric Submersible Pumps	
	3-Phase	
Motor	Type	Induction Motor
	Poles	4 Pole
	Insulation	Class F
	Protector	Circle Thermal Protector
	Starter	D.O.L.
Lubricant	Food Grade (ISO VG32)	
Impeller Type	Opened or Strainer Options	
Shaft Seal	Double Mechanical Seal	
	Silicon Carbide VS Ceramic / Carbon	
Bearings	C3 Shielded ball bearings	
Cable	PVC (CSA Certified) / H07BQ-F	
	10m (33ft) or longer upon request.	
Materials	Pump Casing	Ductile Iron
	Impeller	Chromium Iron
	Motor Frame	Gray Iron
	Motor Shaft	Stainless Steel
	Wear Plate	Chromium Iron
	Agitator	Chromium Iron
Max. Liquid Temperature	40°C (104°F)	
Max. Submersion Depth	20m (66ft)	
pH Range	pH 5 - pH 8	