

H430H Flooded Suction Pump

High Head
Slurry Pump

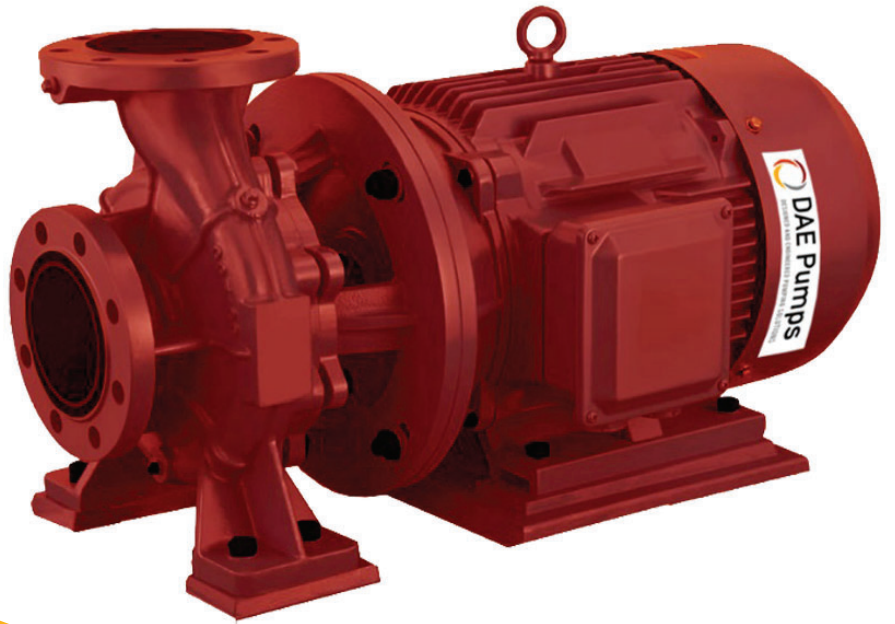

DAEPUMPS.COM

info@daepumps.com

(760) 821-8112

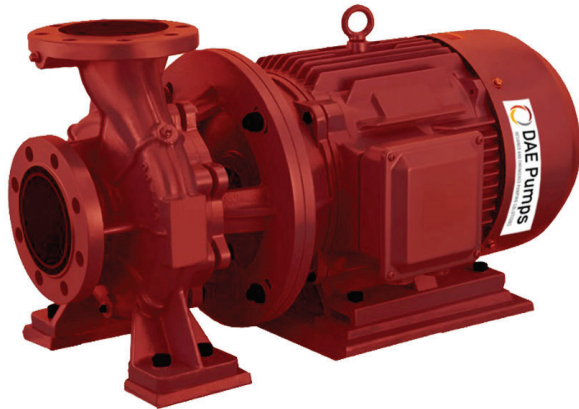

H430H Flooded Suction Pump

Heavy duty, horizontal slurry pumps. High efficiency transfer of abrasive and high-density slurries with extended wear life and reliable service intervals

VERSATILE HEAVY-DUTY SOLUTION

DAE Pumps H430H flooded suction pumps are heavy duty horizontal slurry pumps designed to handle the transfer of abrasive and high-density slurries in mining and heavy industry.

H430H pumps feature a rugged cast iron construction with replaceable wear liners available in 27% chrome white iron, rubber or urethane to suit a wide range of applications, slurry types and consistencies.

The H430H pumps are 3-inch discharge and feature high efficiency performance capable of flow rates up to 1600 GPM and a head up to 405 ft.

They are designed to be interchangeable with the most common slurry pump footprints used by the mining industry.

H430H pumps are manufactured using the highest quality materials to ensure reliability and extended service life in heavy duty applications. H430H pumps are manufactured with a rugged cast iron outer casing which features reinforcing ribs for excellent high-pressure strength and safety.

WEAR LINERS

A range of replaceable wear liners are available in 27% chrome white iron, rubber or urethane to suit the requirements of specific applications and slurry types. Wear liners are easily replaced when required by simply removing the front cover plate bolts and sliding off the front cover. This allows minimal downtime and simple servicing for maintenance staff.

FEATURES

4" Intake / 3" Discharge

1600 GPM

Over 405 Ft. Head

27% Chrome White Iron

IMPELLERS

The impeller features pump-out vanes on the rear face to prevent recirculation. Impellers are available in 27% chrome white iron or rubber to suit the requirements of the pumped product and are easily accessible by simply removing the front cover plate bolts and sliding off the front cover.

EXTERNAL IMPELLER ADJUSTMENT

An external impeller adjustment bolt is located under the bearing assembly and is easily accessible. This allows for changes to be made to the impeller clearance to maximize efficiency and service life without removing the front cover plate or disconnecting pipe-work or the bearing assembly. The system allows quick and simple adjustments to be made to compensate for wear and changes in operating conditions and duty points.

H430H Flooded Suction Pump Specifications

Inlet/Outlet	Max Power	Max Particle Size	Impeller	No. of Vanes	Impeller Material	Impeller / Vane Dia.	Wear Liner Material
4" / 3"	160HP / 120 kW	1.5" / 38 mm	MEH3147	5	27% Chrome White Iron	20" / 518 mm	27% Chrome White Iron

Dimensions (mm)															Weight
A	B	C	D	Key	E	F	G	H	J	K	L	M	N	U	Metal
1240	622	448	457	22x14	222	492	492	330	432	-	51	248	79	80	1250 kg (2756 lbs)

Pump Curve

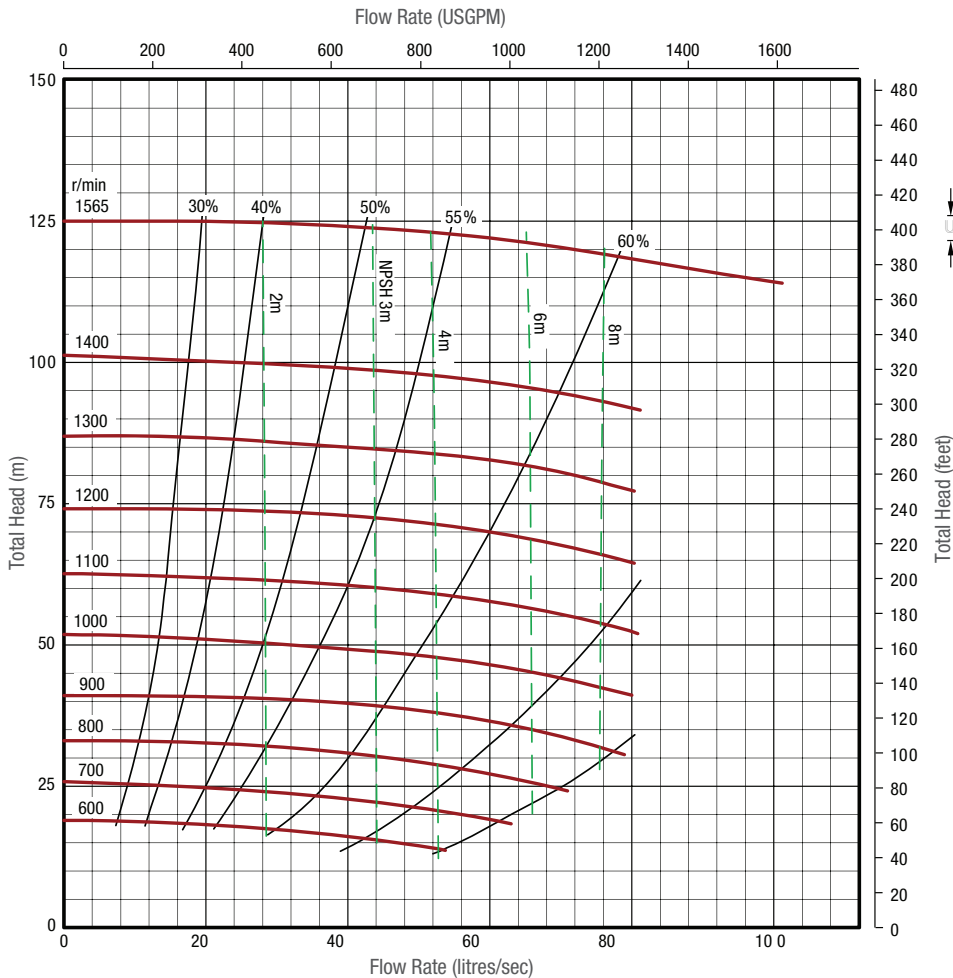

Dimensions

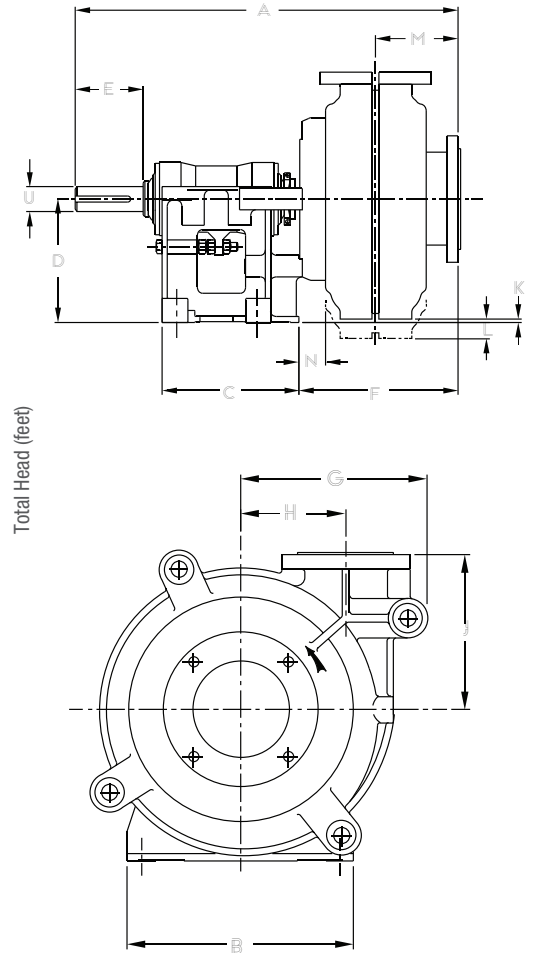

Performance curve is for clean, cold water only. Contact us to discuss pump selections for specific applications.

Materials

Metal Lined Pumps

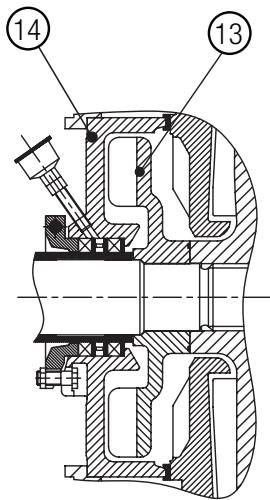

METAL EXPELLER

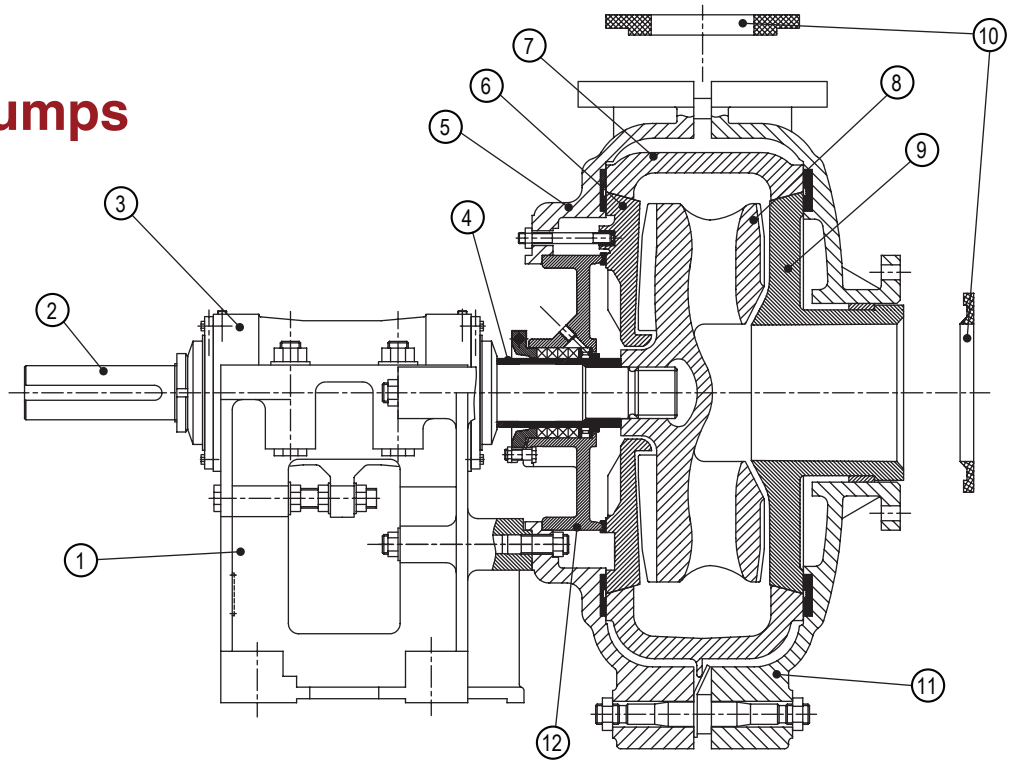

No.	Part Description	Material Specification
1	Base	Cast Iron
2	Shaft	4140 High Tensile Steel*
3	Bearing Assembly	Timkin (Cast Iron Body)
4	Shaft Sleeve	420 Stainless Steel
5	Pump Casing	Cast Iron
6	Frame Plate Liner	27% Chrome White Iron
7	Volute Liner	27% Chrome White Iron
8	Impeller	27% Chrome White Iron
9	Throat Bush	27% Chrome White Iron
10	Joint Rings	Rubber
11	Cover Plate	Cast Iron
12	Stuffing Box	Cast Iron
13	Expeller	27% Chrome White Iron
14	Expeller Ring	Natural Rubber
	Bolts	Zinc Plated Steel
	O-rings	Nitrile Rubber
	Seals	Rubber

* Other shaft material options are available.

