

H1210 Flooded Suction Pump

Metal Liner And Impeller

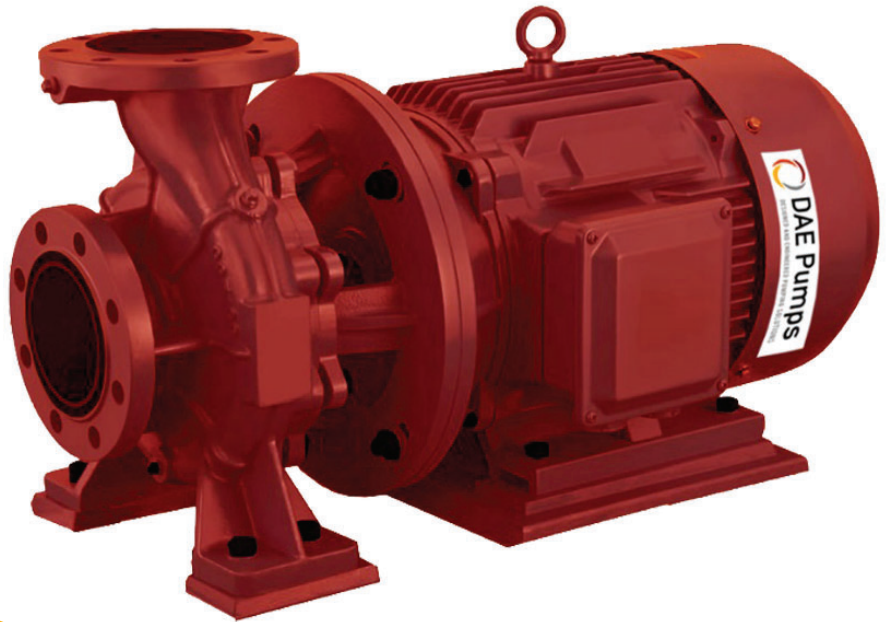

DAEPUMPS.COM

info@daepumps.com

(760) 821-8112

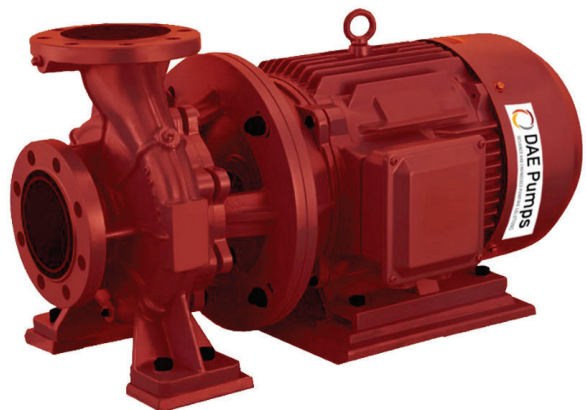

H1210 Flooded Suction Pump

Heavy duty, horizontal slurry pumps. High efficiency transfer of abrasive and high-density slurries with extended wear life and reliable service intervals

VERSATILE HEAVY-DUTY SOLUTION

DAE Pumps H1210 flooded suction pumps are heavy duty horizontal slurry pumps designed to handle the transfer of abrasive and high-density slurries in mining and heavy industry.

H1210 pumps feature a rugged cast iron construction with replaceable wear liners available in 27% chrome white iron, rubber or urethane to suit a wide range of applications, slurry types and consistencies.

The H1210 pumps are 10-inch discharge and feature high efficiency performance capable of flow rates up to 9000 GPM and a head up to 215 ft.

They are designed to be interchangeable with the most common slurry pump footprints used by the mining industry.

H1210 pumps are manufactured using the highest quality materials to ensure reliability and extended service life in heavy duty applications. H1210 pumps are manufactured with a rugged cast iron outer casing which features reinforcing ribs for excellent high-pressure strength and safety.

WEAR LINERS

A range of replaceable wear liners are available in 27% chrome white iron, rubber or urethane to suit the requirements of specific applications and slurry types. Wear liners are easily replaced when required by simply removing the front cover plate bolts and sliding off the front cover. This allows minimal downtime and simple servicing for maintenance staff.

FEATURES

12" Intake / 10" Discharge

9000 GPM

Over 215 Ft. Head

27% Chrome White Iron

IMPELLERS

The impeller features pump-out vanes on the rear face to prevent recirculation. Impellers are available in 27% chrome white iron or rubber to suit the requirements of the pumped product and are easily accessible by simply removing the front cover plate bolts and sliding off the front cover.

EXTERNAL IMPELLER ADJUSTMENT

An external impeller adjustment bolt is located under the bearing assembly and is easily accessible. This allows for changes to be made to the impeller clearance to maximize efficiency and service life without removing the front cover plate or disconnecting pipe-work or the bearing assembly. The system allows quick and simple adjustments to be made to compensate for wear and changes in operating conditions and duty points.

H1210 Flooded Suction Pump Specifications

Inlet/Outlet	Bearing Frame	Max Power	Max Particle Size	Impeller	No. of Vanes	Impeller Material	Impeller / Vane Dia.	Wear Liner Material
12" / 10"	ST X (743)	750 HP / 560 kW	3.4" / 86 mm	FAM10147 G10147	5	27% Chrome White Iron	30" / 762 mm	27% Chrome White Iron
		750 HP / 560 kW						

	Dimensions (mm)															Weight
	A	B	C	D	Key	E	F	G	H	J	K	L	M	N	U	Metal
12x10 F	1721	991	705	610	28x16	279	753	756	464	673	-	104	381	108	100	3760 kg (8290 lbs)
12x10 ST	1816	1150	780	650	32x18	280	762	755	464	673	-	65	381	117	120	4309 kg (9500 lbs)

Pump Curve

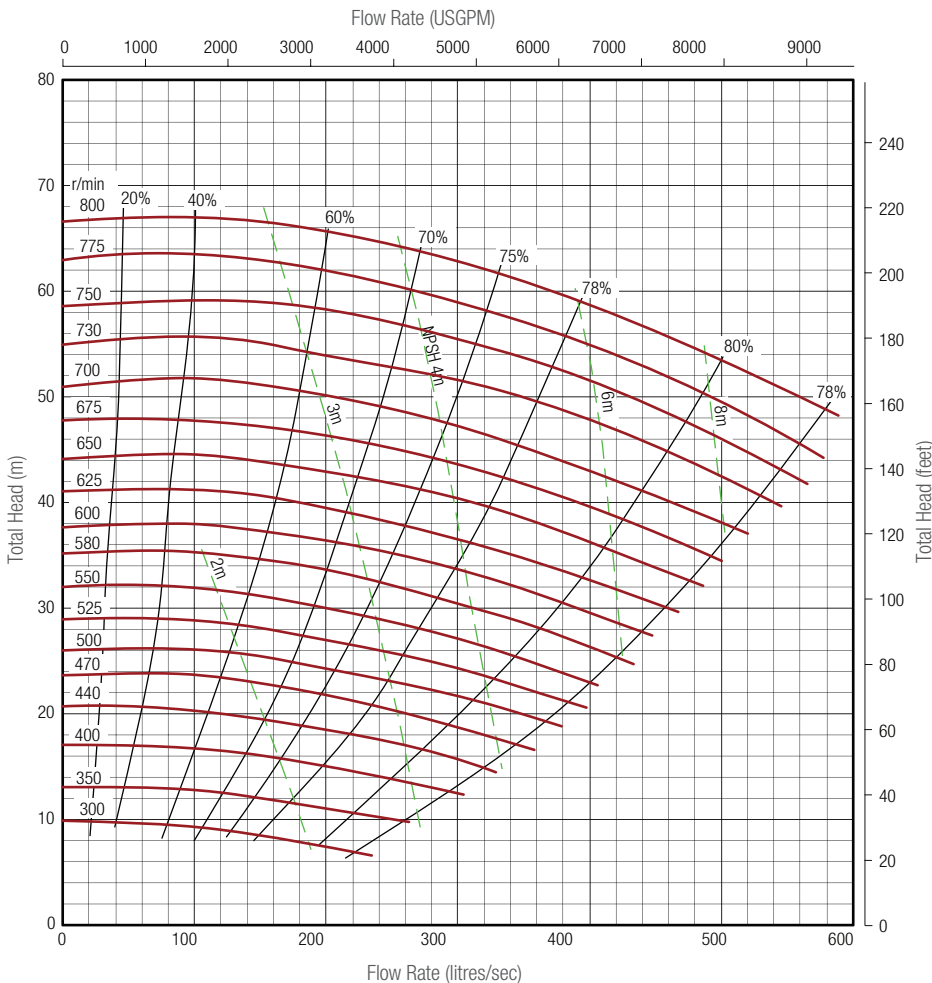

Performance curve is for clean, cold water only. Contact us to discuss pump selections for specific applications.

Dimensions

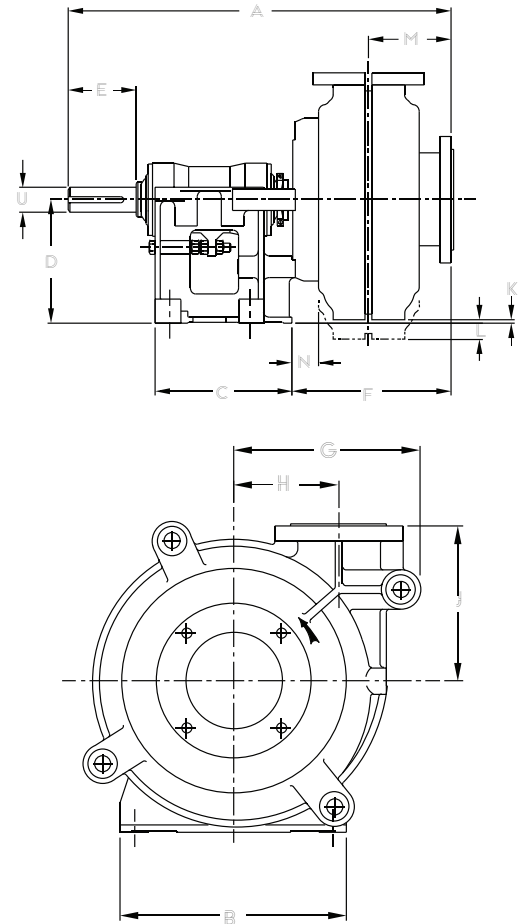

Materials

Metal Lined Pumps

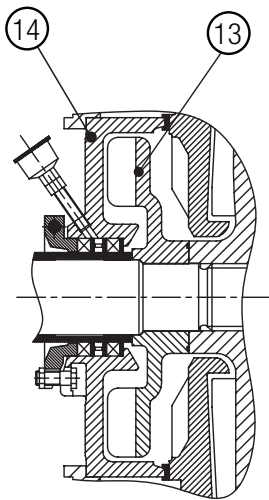

METAL EXPELLER

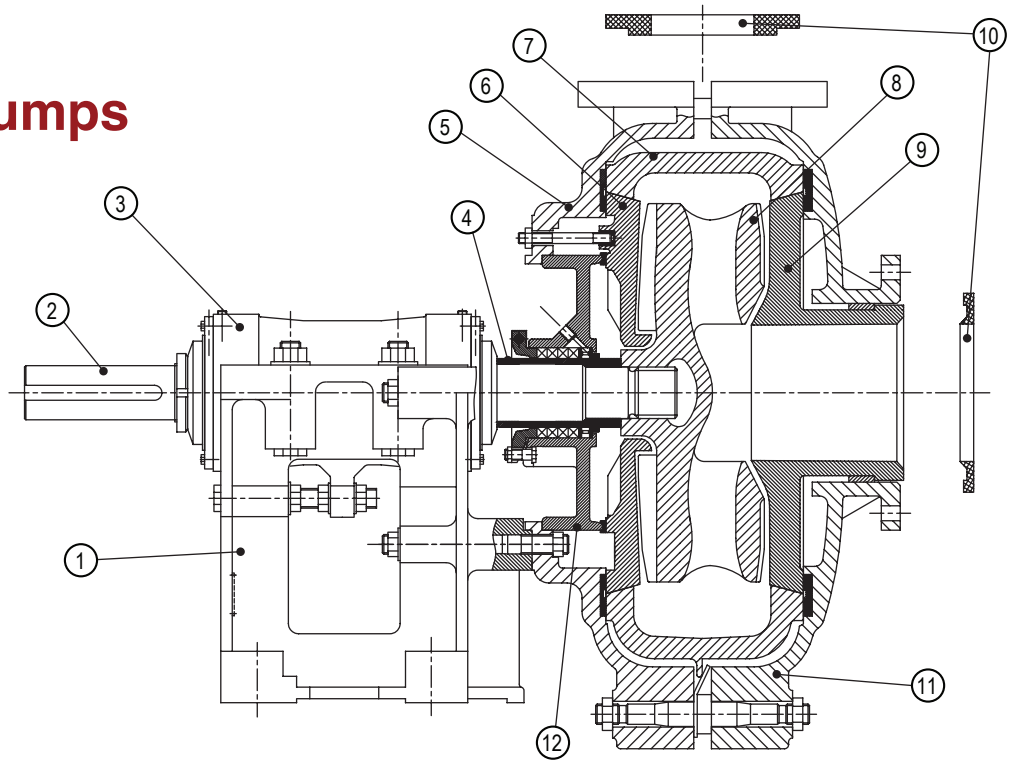

No.	Part Description	Material Specification
1	Base	Cast Iron
2	Shaft	4140 High Tensile Steel*
3	Bearing Assembly	Timkin (Cast Iron Body)
4	Shaft Sleeve	420 Stainless Steel
5	Pump Casing	Cast Iron
6	Frame Plate Liner	27% Chrome White Iron
7	Volute Liner	27% Chrome White Iron
8	Impeller	27% Chrome White Iron
9	Throat Bush	27% Chrome White Iron
10	Joint Rings	Rubber
11	Cover Plate	Cast Iron
12	Stuffing Box	Cast Iron
13	Expeller	27% Chrome White Iron
14	Expeller Ring	Natural Rubber
	Bolts	Zinc Plated Steel
	O-rings	Nitrile Rubber
	Seals	Rubber

* Other shaft material options are available.

