

# Appalachian 1212V

## Self-Priming Surface Pump



**DAEPUMPS.COM**

info@daepumps.com

(760) 821-8112

# Appalachian 1212V

Diesel / 285 HP / 8,600 GPM / 225' Head



## Appalachian Series

The pump system consists of a centrifugal pump and a separator, which enables air to be separated from the liquid and be sucked by a vacuum pump - making automatic priming possible. Even with suction heights of several meters the machine rapidly evacuates the air from the suction pipe and starts to pump. Additionally, thanks to the semi-open impeller, the Appalachian range is also suitable for pumping liquids with solids in suspension.

## Applications

The Appalachian 1212V pump is designed to withstand toughest applications and delivers best in class pumping efficiency. One of the most common area of utilization is the municipal segment where reliability, efficiency and versatility is the key to provide a customized solution. Other suitable applications within Construction and General dewatering, Oil & Gas as well as General Industry are ideal for the Appalachian 1212V pump. Self-priming pumps by DAE Pumps are packed with features that not only meet but exceed the needs of our customers.

Test according to UNI EN ISO 9906 standard - level 2  
Test liquid: clean water, density 62.43 lb/ft (8.345 lb/gal)  
Losses from priming system and check valve not included

Speed	Impeller Dia.	Solids Dia.	Ns	Suction	Discharge	No. Vanes
Various	17" / 440 mm	3.5" / 89 mm	1600 rpm	12" / 300 mm	12" / 300 mm	2

## Benefits

### Efficiency

The 17" impeller with 74% efficiency at B.E.P. provides best pumping result with minimal efforts

### Solid's handling

Closed impeller type with solids handling capability of 3.5" for trouble free operation

### Extended fuel valve connection

Extended fuel autonomy with standard equipped fuel valve connection

### Serviceability

Large doors for superior access and fast service

### Always in control

Suction and discharge gauges visible located to be always in control

## Performance Curve

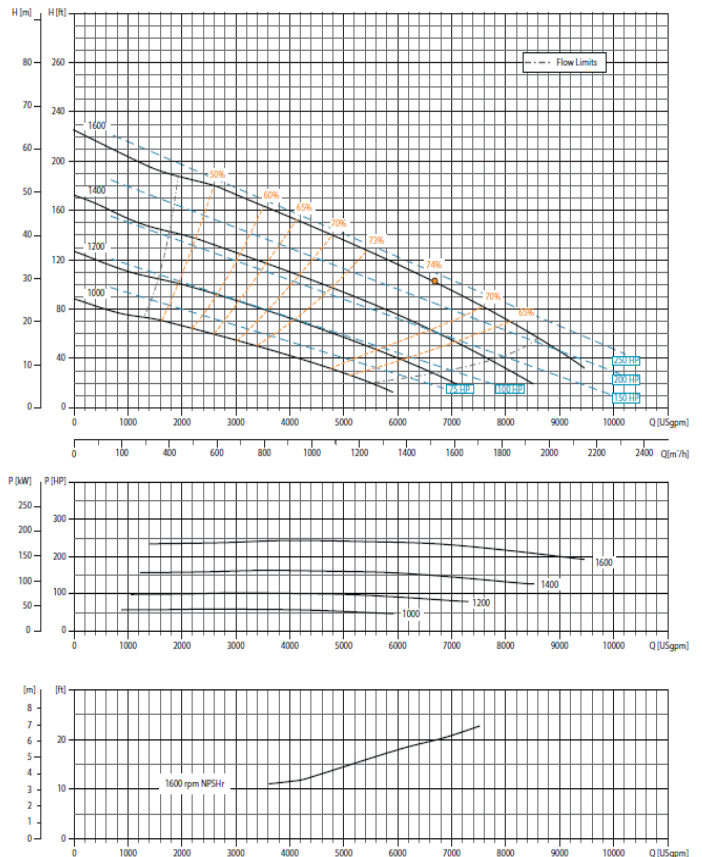

## Technical data

### Pump

<b>Model</b>	<b>Appalachian 1212V</b>
Qmax	8,600 GPM
Hmax	225 ft
Q max eff.	6,715 GPM
Eff. max	74 %
Suction port	12" Flanged - ANSI class 150
Delivery port	12" Flanged - ANSI class 150
Impeller type	Enclosed, 2 vane
Solids handling	3.5"
<b>Material</b>	<b>G11</b>
Casing	ASTM A536 ductile iron
Impeller	ASTM A743 CA6NM
Wear ring	ASTM A48 Class 20 cast iron
Shaft	AISI 630 stainless steel
Mechanical seal	Silicon carbide vs Silicon Carbide
Elastomers	VITON
Check Valve	ASTM A536 ductile iron + NBR rubber flap
Separator	Fabricated Steel

### Priming system

<b>Vacuum pump</b>	<b>V22</b>
Vacuum pump type	Diaphragm
Nominal air capacity	50.0 cfm
Max vacuum	- 26.6 inHg
Drives	Link belt

### Engine

<b>Make</b>	<b>Volvo</b>
Model	TAD 872 VE
Type	Diesel turbo common rail
Displacement	7.7 Liter (470 in <sup>3</sup> )
No. cylinders	6
Cooling	Liquid with radiator
Rpm type	Variable
Standard speed	1,600 rpm
US emissions	EPA Tier 4F
Starting	Electric
Engine system voltage	14 V
Engine Power Rating	285 HP

### Control panel

<b>Model</b>	<b>PW 750</b>
Manual operation	
Automatic operation: start-stop with transducers or floats	
FleetLink Optional	

## Arrangement

Technical data	
Material	ASTM A36 steel
Coatings	Epoxy powder, average thickness of 3 MIL
Features	Lifting beam. Forklift pockets. Optional Lockable doors. Optional Soundproof canopy
Battery	Acid charge Pb-Ca maintenance free 12V – 1150 CCA
Fuel Tank Capacity	119 Gallon
Fuel Consumption	13.5 US Gal/hr @ 1600 RPM @ 73% eff.
Dry Weight	7,720 lbs. (Open) / 9,480 lbs. (Enclosed)
Wet Weight	8,950 lbs. (Open) / 10,580 lbs. (Enclosed)

## Dimensional Drawing

Open

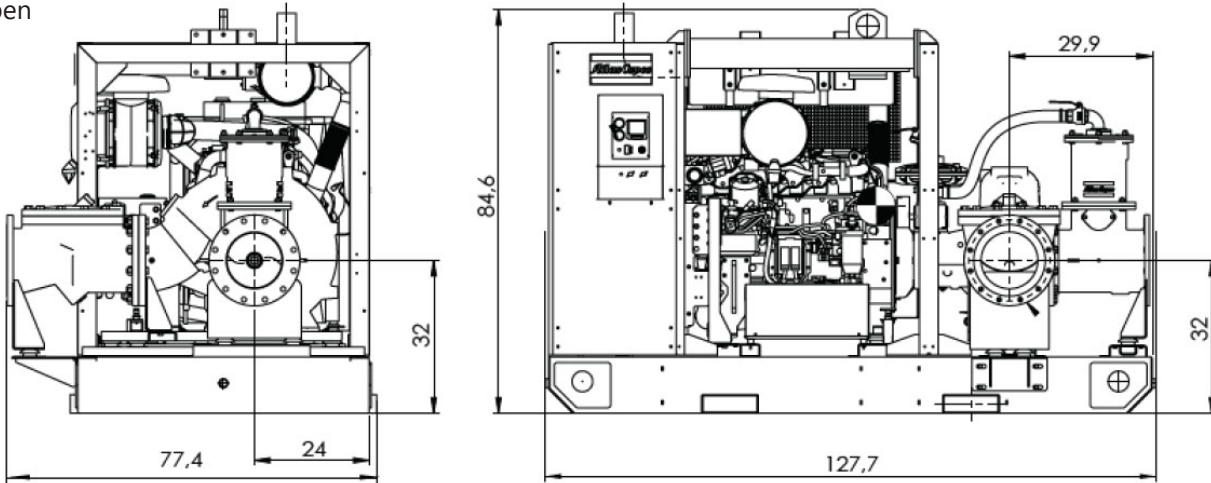

Enclosed

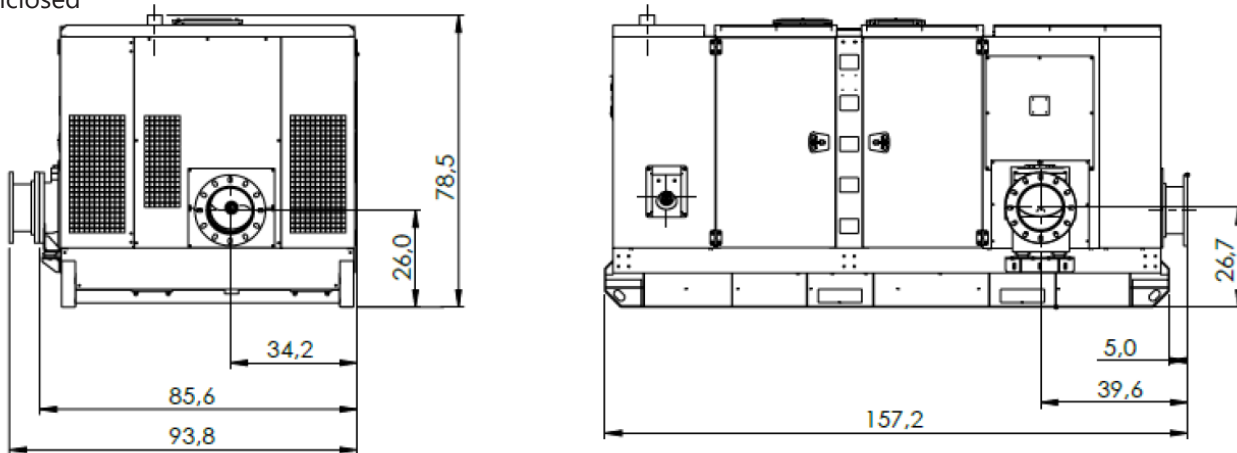

Inches