

VISIT SITE NOW >>

HORTON 330

Mobile Generator



DAEPUMPS.COM

info@daepumps.com

(760) 821-8112

VISIT SITE NOW »

HORTON 330 MOBILE GENERATOR

Multiple voltage, 50/60Hz switchable -
330kVA prime power – JD engine



STANDARD SCOPE OF SUPPLY

DAE Pumps Horton 330 JD T4F generators are prime power, multi-voltage, sound attenuated, mobile generators. They are powered by a JD T4 Final liquid-cooled, six-cylinder diesel engine.

The units consist of an alternator, diesel engine, cooling system, electrical distribution and control systems - all enclosed within a sound attenuated enclosure fabricated from powder coated steel.

A broad range of undercarriage formats and options are available.

Special attention has been given to the overall product quality, user friendliness, ease of serviceability, and economical operation to ensure best in class total cost of ownership.

STANDARD FEATURE

- Compact, sound attenuated, corrosion resistant, with single point lifting and 110% fluid containment
- Dual axle trailer as standard, available as a skid mounted unit with forklift pockets as an option
- Heavy Duty alternator with AREP excitation and marine grade protection
- Single side service with long run filters and 500-hour service intervals
- John Deere 6090HFG06 with Variable Speed Fan and ETM system
- Voltage selector switch (4 positions)
- Battery Charger (24V, 12A)
- External Fuel Tank connections (3-way valve) located inside the enclosure
- Internal Lights
- Identical enclosures and maintenance points between models
- Emergency Stop
- Remote signal Start / Stop

BENEFITS

- Extremely durable and environmentally sensitive, designed to be used for everything from the oil field to special event power
- Versatility, giving you the flexibility to match your machine to the correct application
- Start-up power for the most demanding sites with 300% overload starting capabilities
- Heavy duty oil, air and fuel filters extend the maintenance interval to 500 hours for reduced total cost of ownership
- Proven engine platform with high reliability and durability, along with VSF and Exhaust Temperature Management system that minimizes the risks of wet stacking
- Simple voltage change within seconds
- On board charger to ensure the battery is always ready for service
- Flexibility to work with an external and larger fuel tank for extended autonomy
- Safety and convenience when servicing the unit
- Reduces stock of service kits and inventory of parts with rental ROI kept in mind
- External, recessed emergency stop for increased safety
- Allows connection as a critical back-up unit via a 2-wire dry contact connection in the distribution panel

VISIT SITE NOW »

[VISIT SITE NOW >>](#)

TECHNICAL DATA¹

Generator	Units	Horton 330	
Frequency	Hz	50	60
Rated Prime Power @ 400V/50Hz & 480V/60Hz 3Ø	kW / kVA	224/280	264/330
Rated Standby Power @ 400V/50Hz & 480V/60Hz 3Ø	kW / kVA	246/308	290/363
3Ø Power Factor		0.8	0.8
3Ø Voltage @ 480V 60Hz (Series Star w/Neutral)	V	-	480Y/277
Amp Capacity @ 480V 60Hz 3Ø	A	-	397
3Ø Voltage @ 240-208V 60Hz (Parallel Star w/ Neutral)	V	-	240Y/139 – 208Y/120
Rated Prime Power @ 240V 3Ø 60Hz	kW / kVA	-	264/330
Amp Capacity @ 240V 60Hz 3Ø	A	-	794
Rated Prime Power @ 208V 3Ø	kW / kVA	-	231/288
Amp Capacity @ 208V 60Hz 3Ø	A	-	800
Rated Prime Power 1Ø @ 120-240V 60Hz	kW / kVA	-	192 / 192
1Ø Power Factor		-	1.0
1Ø Voltage @ 120-240V 60Hz (Zig-Zag)	V	-	240/120
Amp Capacity @ 240V 60Hz 1Ø	A	-	800
Amp Capacity @ 120V 60Hz 1Ø	A	-	2 x 800
3Ø Voltage @ 400V 50Hz (Series Star w/Neutral)	V	400Y/231	-
Amp Capacity @ 400V 50Hz 3Ø	A	404	-
Performance Class (acc. ISO 8528-5:1993)		G2	G2
Single Step Load Acceptance (0-PRP)	kW (%)	121 (54%)	163.7 (62%)
Sound Pressure Level @ 23'(7 m) @ 75% Load ²	dB(A)	70	73
Alternator (4 Pole, 12 Wire)	Leroy Somer	LSA 46.2 L9	
Excitation system		AREP (auxiliary winding)	
AVR - Automatic Voltage Regulator model		R450 (std) / DVC 550 (parallel option)	
AVR's AC voltage regulation accuracy	%	±0.5% (R450) / ±0.25% (DVC 550)	
Insulation		Class H	
Main Breaker – Rated Current In	A	1000	
Power Distribution – Terminal Board		5 Wire (L1, L2, L3, N, Ground)	
Terminal Board Connections		Bare Wire Terminals	
Maximum Terminal Cable Size		350MCM	
Convenience Receptacles ³		N/A	(2) NEMA 5-20R GFCI & (2) 125/250V 50A CS6369

Fuel & DEF Systems	Units	Horton 330		
Fuel Consumption @ 25% load	50Hz / 60Hz	US Gal/hr (L/hr)	5.1 (19.2)	6.10 (23.09)
Fuel Consumption @ 50% load	50Hz / 60Hz	US Gal/hr (L/hr)	7.8 (29.5)	9.48 (35.88)
Fuel Consumption @ 75% load	50Hz / 60Hz	US Gal/hr (L/hr)	11.9 (44.9)	13.55 (51.29)
Fuel Consumption @ 100% load	50Hz / 60Hz	US Gal/hr (L/hr)	15.2 (57.7)	18.29 (69.23)
Fuel Type		Ultra-Low Sulfur Diesel ONLY ⁴		
Fuel Tank Capacity		US Gal (L)	385 (1457)	
Fuel Autonomy @ 75% load and 90% of fuel capacity		Hr	29.1	25.6
DEF Tank Capacity		US Gal (L)	25 (94.6)	

[VISIT SITE NOW >>](#)

VISIT SITE NOW »

Engine	Units	Horton 330
Model	John Deere	6090HFG06
US EPA Family		MJDXL09.0313
US EPA Tier		Tier 4 Final
Displacement	L	9
Cylinders	#	6
Continuous Engine Power Output	HP (kW)	399 (298)
Gross Engine Power Output	HP (kW)	437 (326)
Rated Speed	RPM	1800
Engine Control		ECU
Aspiration		Turbocharged w/ Intercooler
Engine oil capacity ⁵	US Gal (L)	10.6 (40)
Engine coolant capacity	US Gal (L)	13.6 (51)
Maximum Ambient Temperature (@ Sea Level) ⁶	°F (°C)	122 (50)
Min. Starting Temp (w/o heater)	°F (°C)	14 (-10)
Minimum Starting Temperature (with heater) ⁷	°F (°C)	-13 (-25)
Electrical System (Negative Ground)	V	24
Engine Alternator Output	A	60
Battery Capacity (Cold Cranking Amps)	A	(2) 1100

- 1 All ratings are at a reference condition of 0' altitude and 20°C (72°F)
- 2 Measured in accordance with ISO 2151 under free field conditions @ 7m distance
- 3 Please see receptacle voltage configuration in Power Distribution section on page #5
- 4 Engine and emissions require the use of Ultra Low Sulfur Diesel in accordance to ASTM-D975 Grade No.1-D S15 & No.2-D S15
- 5 Engine oil to meet CJ-4 (low ash oil)
- 6 Please see "Derate Table" for altitude and temperature calculations on page #4
- 7 Coolant Heater (120V 1000W) is a standard feature.

DIMENSIONS

Trailer Mounted

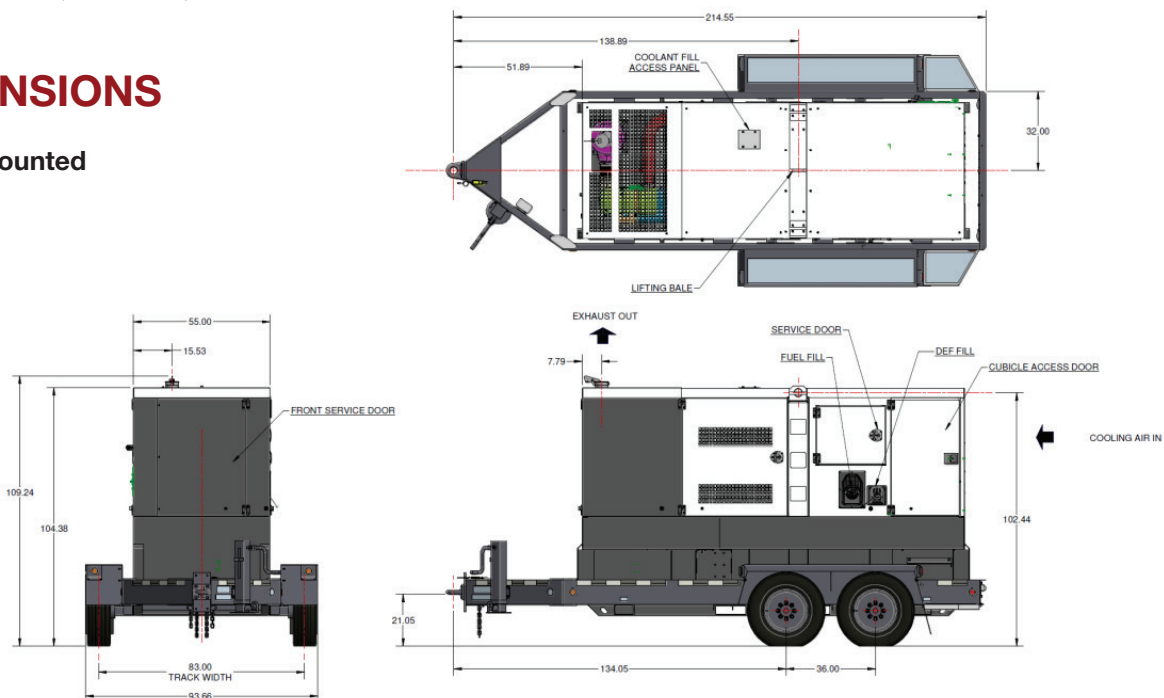

VISIT SITE NOW »

VISIT SITE NOW »

Skid Mounted

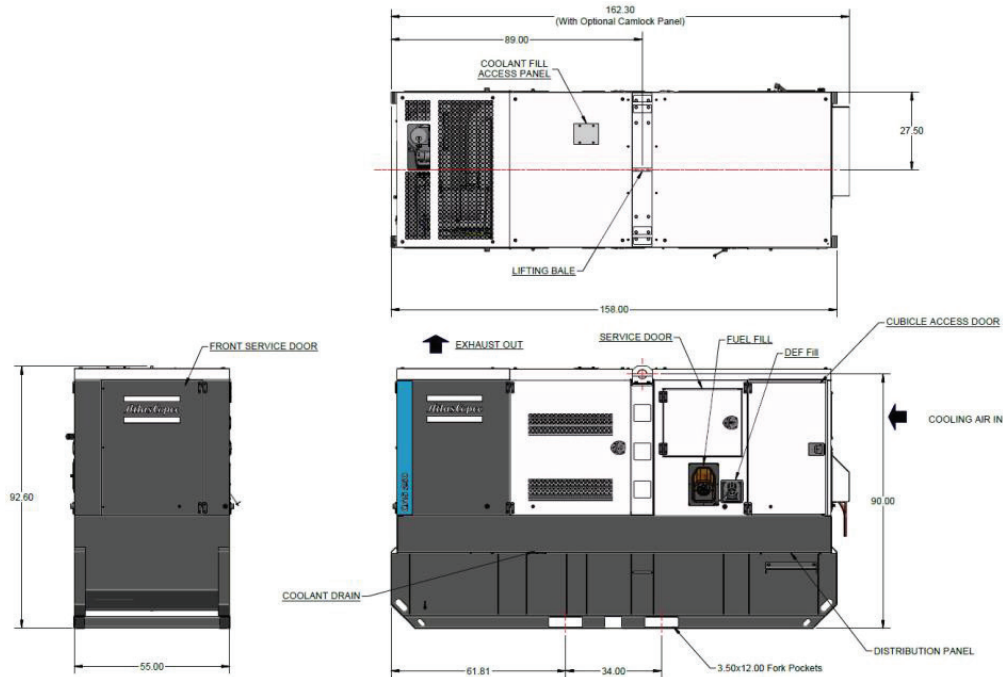

Weight	Units	Horton 330
Trailer Mounted – Wet (ready to operate)	lbs (Kg)	14,355 (6,511)
Trailer Mounted – Dry	lbs (Kg)	11,125 (5,046)
Skid Mounted – Wet (ready to operate)	lbs (Kg)	12,446 (5,645)
Skid Mounted – Dry	lbs (Kg)	9,216 (4,180)

Dimensions	Units	Horton 330
Trailer Mounted (L x W x H)	Inches	218 x 94 x 109
Skid Mounted (L x W x H)	Inches	158* x 55 x 93

*162.3 inches with camlock panel

PRINCIPLE DATA

Alternator

The Leroy Somer LSA alternators are designed for heavy duty continuous applications, with marine winding protection and Leroy Somer's AREP excitation system.

- AREP Excitation for superior motor starting capabilities
- Marine grade (relative humidity >95%) protection
- External multi-voltage selector switch (4-position)
- 4 pole brushless design with single bearing, Class H insulation and IP23 rating
- Voltage regulation +/- 0.5%
- Full Load acceptance of prime power rating

VISIT SITE NOW »

VISIT SITE NOW >>

The AREP system uses 2 independent auxiliary windings located in the main stator to send supply voltage to the AVR:

- The voltage delivered by the first auxiliary winding H1 is proportional to the alternator output voltage (shunt characteristic)
- The voltage delivered by the second auxiliary winding H3 is proportional to the current drawn by the alternator and is a function of the applied load (compound characteristic – booster effect)
- The resulting phase-to-phase voltage supplies power to the AVR

This power supply to the AVR power circuit is independent of the voltage sensing measured on the alternator output terminals. Therefore, the excitation current delivered by the AVR to the alternator exciter is independent of any voltage distortions (harmonics) due to the load.

The AREP system gives the alternator a high overload capacity (load impact or starting electric motors) and a short-circuit capability (300% - 10 s) in order to provide discriminating protection: the alternator with AREP excitation is shorter than the one with PMG excitation. It is particularly suitable for demanding applications.

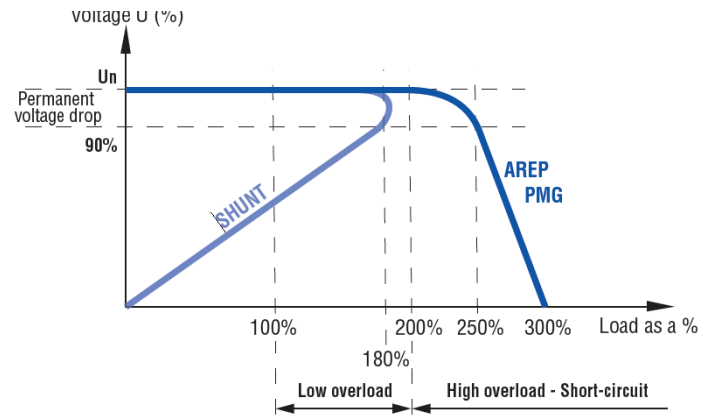
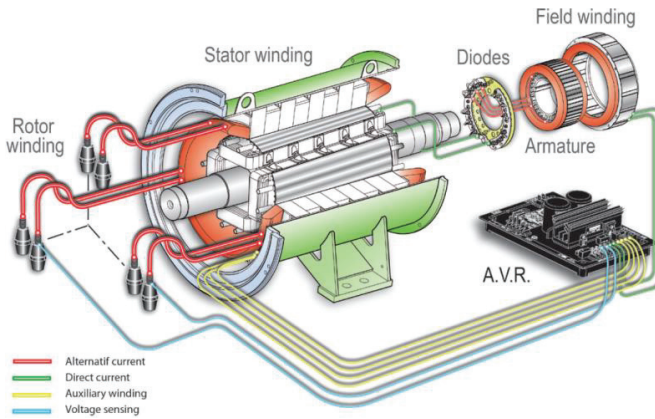

PERFORMANCE @ ALTITUDE AND HIGH AMBIENT CONDITIONS

When using at altitude and high ambient conditions the engine and alternator will de-rate as per chart below.

Horton 330 Height m (Feet)	Temperature °C (°F)										
	0 (32)	5 (41)	10 (50)	15 (59)	20 (68)	25 (77)	30 (86)	35 (95)	40 (104)	45 (113)	50 (122)
0	100%	100%	100%	100%	100%	100%	100%	100%	100%	95%	90%
500 (1640)	100%	100%	100%	100%	100%	100%	100%	100%	100%	95%	90%
1000 (3280)	100%	100%	100%	100%	100%	100%	100%	100%	100%	95%	90%
1500 (4921)	100%	100%	100%	100%	100%	100%	95%	95%	95%	90%	90%
2000 (6561)	100%	100%	100%	100%	100%	100%	90%	90%	90%	85%	85%
2500 (8202)	95%	95%	95%	95%	95%	95%	85%	85%	85%	80%	75%
3000 (9842)	95%	95%	95%	95%	95%	95%	85%	85%	85%	80%	75%
3500 (11,482)	90%	90%	90%	90%	90%	90%	75%	75%	75%	75%	70%
4000 (13,123)	90%	90%	90%	90%	90%	90%	75%	75%	75%	75%	70%
4500 (14,764)	85%	85%	85%	85%	85%	85%	70%	70%	70%	65%	65%
5000 (16,404)	80%	80%	80%	80%	80%	80%	70%	70%	70%	65%	65%

VISIT SITE NOW >>











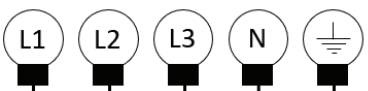

VISIT SITE NOW »

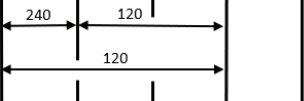
POWER DISTRIBUTION

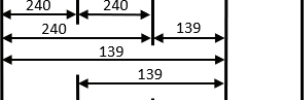
The main power is connected from the alternator through a 4-position voltage selector switch to the main power cubicle. The cubicle incorporates all power distribution, controls, sensing and protection devices.

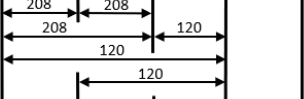
- 4- position Voltage Selector Switch (VSS)
- Current transformer x 3 (1 each leg)
- Single main breaker w/shunt trip
- Individual breakers for each receptacle
- Convenience receptacles located on outside of unit for easy access
- Terminal board for hard wiring
- Cam-Lock external quick connect (available as option)
- External emergency stop switch (recessed)
- Neutral bonded to Ground with a removable bonding link accessible in the control cubicle

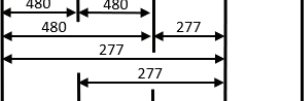
Please refer to the chart below for power distribution and voltages. NOTE: All voltages below are subject to change, depending on set point of “Fine Voltage Adjustment” potentiometer and Voltage Selector Switch.

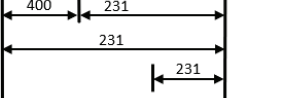
		120V Receptacle NEMA 5-20R	125/250V Receptacle CS6369	Terminal Board
Fine Voltage Adjustment	Voltage Selector Switch Position			
	 240/120V 1Ø 60Hz	120V	240/120V	
	 240/139V 3Ø 60Hz	139V	240/139V	
	 240/139V 3Ø 60Hz	120V	208/120V	
	 480/277V 3Ø 60Hz	139V	240/139V	
	 400/231V 3Ø 50Hz	N/A	N/A	

*All voltages are adjustable with the “Fine Voltage Adjustment” potentiometer located on the control panel. Therefore, voltage may be different than what is shown in the above table. All voltages should be verified before connection to the unit.

VISIT SITE NOW »

VISIT SITE NOW »»

CONVENIENCE RECEPTACLES

Receptacle	Type
X2, X3	120V - NEMA 5-20R GFCI (outlets)
X4, X5	125/250V - CS6369 (outlets)
X7	120V - NEMA 5-15P (shore power inlet for coolant heater and battery charger)

CONTROLLER - STANDARD

The Horton 330 come equipped with a DeepSea 7310 control module. This is a fully diagnostic ECU controller with large 3" display, that is intuitive and easy to operate with all functions conveniently at your fingertips. The controller also manages the engine ECU operating system, and a number of safety warnings and shutdowns on various parameters (listed below).

The controller is powered by a main on/off switch located next to unit.

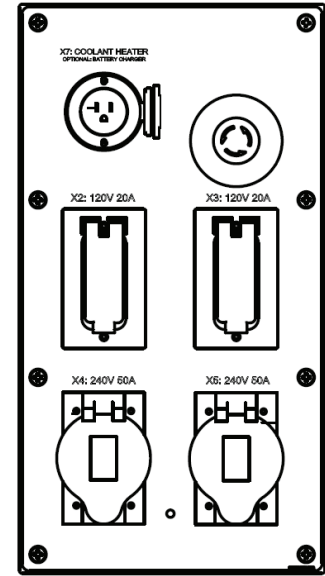

DEEPSEA 7310 CONTROLLER FUNCTIONALITY:

- Home Page (displayed while running, scrolling every 3seconds)
 - » Generator voltage (ph-ph)
- Status Page
 - » Generator voltage (ph-N)
 - » Generator voltage (ph-ph)
 - » Generator frequency
 - » Generator kw
 - » Generator power factor
 - » Generator amperage
- Generator Page
 - » Generator current (A)
 - » Generator earth current
 - » Generator load (kw)
 - » Generator load (kVA)
 - » Generator power factor
 - » Generator load (kVAr)
 - » Generator load (kWh, kVAh, kVArh)
 - » Generator phase sequence
 - » Dual mutual status
- Event Page
 - » Displays the last 15 events
- Remote Start/Stop
 - » Automatic start/stop via 2 wire dry contact connection
- Operational Buttons
 - » Start button
 - » Stop button
 - » Automatic mode (external remote start)
 - » Up/Down arrows
- Engine Page
 - » Engine speed
 - » Oil pressure
 - » Coolant temperature
 - » Engine battery volts
 - » Run Time
 - » Oil Temperature
 - » Fuel Temperature
 - » Turbo Pressure
 - » Fuel Pressure
 - » Fuel Consumption
 - » Fuel Used
 - » Fuel Level
 - » Auxiliary Sensors
 - » Engine Maintenance Due
 - » Engine ECU Link
- Info Page
 - » Model number
 - » USB identification number
 - » Configured engine type
 - » Module date and time
 - » Scheduler setting
- Engine DTC Page
 - » This page contains any active Diagnostic Trouble Codes that the engine ECU is currently generating. These alarms are conditions detected by the engine ECU and displayed on the DSE controller.



VISIT SITE NOW »»

[VISIT SITE NOW >>](#)

CONTROLLER – PARALLELING OPTION

The Horton 330 is also available as an option with a Qc4004 controller and Qd0701 capacitive touch screen display. This is a fully diagnostic ECU controller with large 7” diagonal (800 x 480 pixel) touch screen display that is intuitive and easy to operate with all functions conveniently at your fingertips. The controller also manages the engine ECU operating system, and a number of safety warnings and shutdowns on various parameters.

Additionally, our Power Management System (PMS) enables the optimization of fuel consumption and expands the generator lifetime. PMS manages the quantity of generators running in parallel with load demand, starting and stopping units in line with increases or decreases in load. This ensures the demand on each generator remains at a level which optimizes fuel consumption. This also eliminates the need for generators to run with low load levels, which can cause engine damage and shorten the life expectancy of the equipment.

Qc4004 Controller Benefits:

- Modular Plant Capacity
 - » The Qc4004 controller allows up to 32 generators to be coupled in parallel to fit the power requirement of any application.
- Remote communication capability
 - » The Qc4004 supports serial communication protocols including Modbus (RS-485, USB, and TCP/IP) and Profibus allowing you to supervise and control your genset/plant remotely.
- User friendly rental interface
 - » Rental companies will benefit from the standardized user interfaces. The controller has been designed with ease of operation in mind, and rental companies can easily set and lock parameters to ensure full protection of their equipment.
- Available Modes:
 - » **Island mode** - Power plant with synchronizing generators or a stand-alone generator. Also applicable in critical power plants.
 - » **Automatic mains failure** - Critical power/emergency standby plants, black start generator.
 - » **Fixed power** - Power plant with fixed kW set point (including building load).
 - » **Peak shaving** - Power plant where generator supplies peak load demand paralleled to the mains.
 - » **Load takeover** - Plant mode where the load is moved from mains to generator, for example peak demand periods or periods with risk of power outages.
 - » **Mains power export** - Power plant with fixed kW set point (excluding building load).
 - » **Remote maintenance** - Used when the generator must supply the load while a distribution transformer is disconnected for service.

** All modes are configurable, and it is possible to change the plant mode on the fly both in single and in power management applications.*



[VISIT SITE NOW >>](#)

VISIT SITE NOW »

ENGINE

John Deere

JD Tier 4 Final, turbo charged, intercooled, six-cylinder, liquid-cooled diesel engine provides ample power to operate the generator continuously at full-load.

Meets all US EPA, CARB and Environment Canada exhaust legislations with Tier 4 Final compliance. The engine utilizes a Selective Catalytic Reduction (SCR) and Diesel Exhaust Fluid (DEF) to meet final Tier 4 emissions. All functionality of the engine is controlled automatically on the controller.

The engine has the capability to start the generator at 14°F (-10°C) with standard glow-plug aid. A 1000W, 110V coolant heater comes as standard and allows a minimum starting temperature of -13°F (-25°C) when using cold weather option (including 0W40 synthetic engine oil).

The 385 Gal (1457L) fuel tank is sufficiently sized to operate the unit at full-load condition for long run times (see the Technical Data table for specifications).

The engine operates on a 24V negative ground electrical system with a charging alternator and lockable battery cutoff switch.

The cooling system is suitably designed for continuous operation in ambient conditions up to 122°F (50°C), with canopy door closed.

Fuel System

A large 385 US Gal (1457L) fuel tank provides safe diesel storage while eliminating tank corrosion contaminants from being introduced to your fuel system. With integrated fuel water separator and filter, the system is designed to help maintain clean and trouble-free diesel supply to the engine for reliable trouble-free operation.

- Pad-lockable diesel fill cap
- Fuel / Water separator
- Inline priming pump (w/ filter)
- Fuel pre-filter
- Fuel supply pump (w/ strainer)
- Fuel level sensor
- Low fuel shut down feature (programmable level)
- External fuel connections w/ 3-way valve and quick-connections

Scheduled maintenance

Standard equipped with filters sized and designed to allow 500-hour service intervals under normal operating conditions. Extended time between services reduces down time and total cost of ownership of the unit over its lifetime.

- 500 Hour Service Interval:
 - » Oil filter
 - » Fuel filter
 - » Fuel / water separator

VISIT SITE NOW »

- 1000 Hour Service Interval:
 - » Air filter
 - » Oil filter
 - » Fuel filter
 - » Fuel / water separator

NOTE: Site specific operating conditions such as; poor fuel quality and low load profile may require more frequent service intervals.

ENCLOSURE & FRAME

The generator enclosure is designed for extreme applications to provide superior performance and reliability.

The enclosure is made of carbon steel which is zinc rich primed, powder coated for corrosion resistance and salt spray tested for 6000 hours. The enclosure and frame are fully sealed from the radiator to the back of the unit, providing a true 110% containment of all fluids.

- 14 Ga carbon steel, zinc rich primed, powder coated enclosure, 6000-hour salt spray tested
- Heavy duty, 3/16" thick steel base frame
- 110% fluid containment
- Superior level of rain ingress protection and design features
- Pad-lockable doors and fuel cap
- Engine fluid plumbed to exterior of frame for ease of service
- Central lifting point
- Sound dampening material and design to allow quiet operation at 73 dB(A)

UNDERCARRIAGE

The Horton 330 is available with two undercarriage alternatives, providing utmost flexibility in installation, site handling or towing. Both the skid frame and the trailer mount the same way and can be interchanged for versatility.

- Trailer mounted
 - » Tandem axle trailer
 - » Electric brakes
 - » DOT/Federal MVSS 49CFR571 approved light package and 6 pin plug
 - » Adjustable height pintle hitch (3" lunette)
 - » 16" Rims w/ ST235/80R16 Tires for trailer use
 - » Heavy Duty torsion axles
 - » 3/8" Safety chains with clevis slip hook and safety latch
 - » Screw jack leveling, with pad foot
 - » Single point lifting structure
 - » Tie down points x4
- Skid mounted
 - » Sub-frame skid with integrated forklift pockets
 - » Heavy duty design for use in extreme conditions
 - » Built-in locations for straps or chains to secure the unit for transport
 - » Single point lifting structure

VISIT SITE NOW »

FACTORY OPTIONS AVAILABLE

- Trailer stabilizer jacks
- Trailer mounted toolbox
- Spare Tire & mount
- Skid mount
- Cold weather kit (PAROIL E ULTRA - 0W40 synthetic engine oil)
- Parallel Cubicle (includes Qc4004 controller + Touch Screen Display, Motorized Breaker, Digital AVR)
- Camlock quick connections (5 x 400A) – standard on RS* and PRS** models
- External Fuel Tank connection (3-way valve) with Racor Dual Fuel Filter – standard on PRS** models

*RS = Rental Spec

**PRS = Premium Rental Spec

MANUFACTURING & ENVIRONMENTAL STANDARDS

The Horton 250 JD T4F are manufactured following stringent ISO 9001 9001 Quality Management requirements, and by a fully implemented Environmental Management & Occupational Health and Safety Systems fulfilling ISO 14001 & ISO 45001 requirements.



Attention has been given to ensure minimum negative impact to the environment.

The Horton 250 JD T4F meets all current US EPA, CARB and Environment Canada exhaust and noise emission directives.

SUPPLIED DOCUMENTATION

The unit is delivered with documentation regarding:

- Hard copies of the **DAE Pumps** Operators Safety and Instruction Manual, **DAE Pumps** Parts Book, JD Engine Manual and Parts book, in English as well as electronic copies available on request.
- Warranty Registration card for engine and **DAE Pumps** Generators (Units must be registered upon receipt).

WARRANTY COVERAGE

DAE Pumps Generator: Warrantied to be free from defects with regard to material and workmanship for the period of eighteen (18) months from date of shipment from the factory, or twelve (12) months from date of initial startup, whichever occurs first, without limitation of running hours.

John Deere Engine: John Deere Diesel engines are warranted to be free from defects with regard to materials and workmanship for the period of twelve (12) months without limitations in running hours, or twenty-four (24) months prior to the accumulation of 2,000 hours from the date of invoicing from **DAE Pumps**.

Leroy Somer Alternator: Warrantied to be free from defects with regard to material and workmanship for the period of twenty-seven (27) months from date of shipment from the factory, or twenty four (24) months from date of initial startup or 10,000 hours, whichever occurs first.

Extended Warranty Programs: Programs are available; please contact your local sales representative for more info.

VISIT SITE NOW »